

PEAKFLO

Butterfly Valve - Resilient Seated Sizes: 50mm - 600mm

Features:

- Lugged and Wafer Designs
- Available to Suit AS2129 Table E, PN16 and ANSI 150 Flange Dimensions
- Fusion Bonded Epoxy Coated Body
- Lever or Gear Operated
- Design Standard: API609
- Face to Face to BS 5155
- Testing to API 598
- Top Flange to ISO 5211 For Actuator Mounting
- Working Pressure: 16 Bar - sizes to 300mm
10 bar - sizes 350-600mm
- Temperature EPDM Seat To 110°C, Nitrile Seat To 90°C
- S/S Notch Plate , Bolts and Nuts With Lever Operated Valve
- Extended Neck Allows For Insulation
- Both Primary & Secondary Stem Seals
- Disc Spherically Machined & Polished For Tight Shut Off & Long Seat Life



Materials:

Part	Material
Body	Cast Iron ASTM A-126 GRB
Seat	EPDM/NBR
Disc	Stainless Steel CF8M/CF8
Stem	Stainless Steel 431
Stem Bushing	Epoxy Glass Fibre Composite
Stem O' Rings	EPDM/NBR
Lever Operator	Ductile Iron
Notch Plate and Bolts	Stainless Steel 304
Body Coating	Fusion Bonded Epoxy

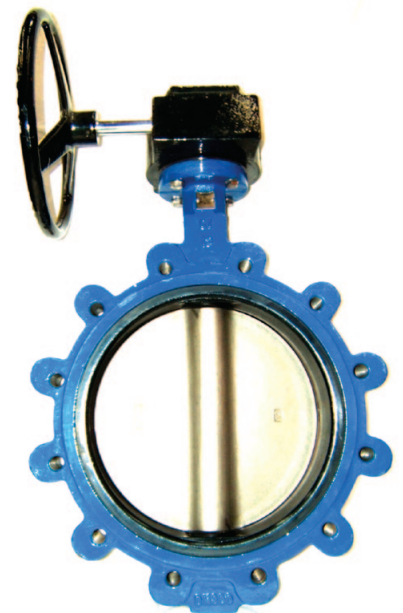

Asmuss Plastic Systems Limited

FREEPHONE: 0800 000 546 Facsimile: (64) (9) 477 - 2328
sales@plasticsystems.co.nz
34 Arrenway Drive, North Shore City 0632
P.O. Box 100244, North Shore City 0745, Auckland, NZ



Dimensions: Lugged Style

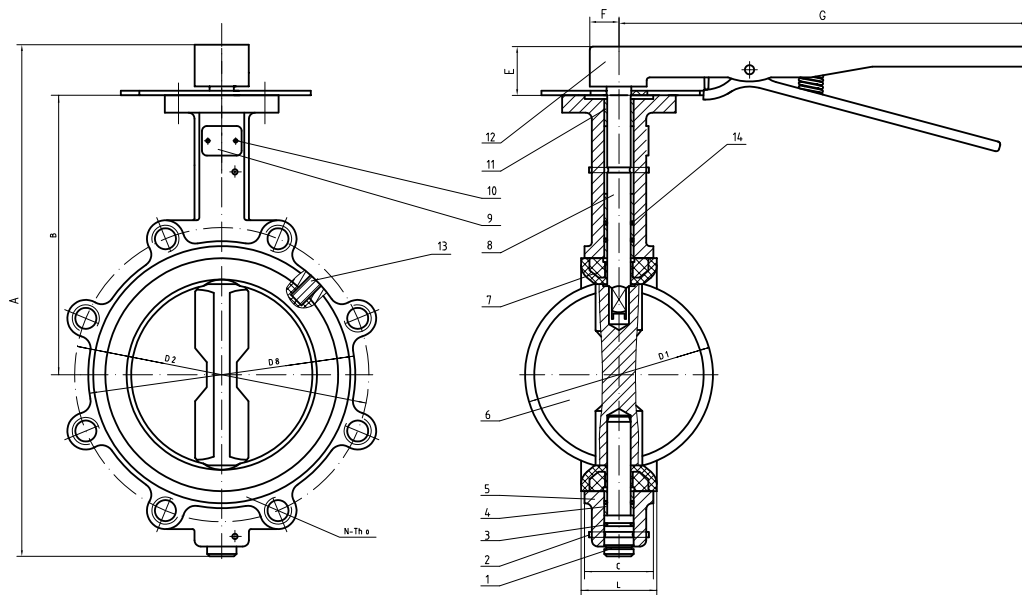

UNIT: mm

DN	D1	D2	N-Th	D8	A	B	C	E	L	F	G	Wgt KG
DN50 (2")	52.6	114	4-M16	100	280	161	43	32	45	12.7	252	5
DN65 (2.5")	54.3	127	4-M16	120	303	175	46	32	47.6	12.7	252	6
DN80 (3")	78.8	146	4-M16	127	315	181	45.21	32	49	12.7	252	6.2
DN100 (4")	104	178	8-M16	165	353	200	52.07	32	54.7	16	252	9
DN125 (5")	123.3	210	8-M16	185	379	213	55.5	32	58	19	252	11.2
DN150 (6")	155.7	235	8-M20	212	404	226	55.75	32	58.6	19	252	12.3
DN200 (8")	202.41	292	8-M20	268	487	260	60.58	45	63.4	31	359	20
DN250 (10")	250.42	356	12-M20	341	553	292	68	51	70	31	359	31.2
DN300 (12")	301.5	406	12-M20	400	637	337	76.9	51	80.1	31	359	51.1

Dimensions: Lugged With Gear Operator

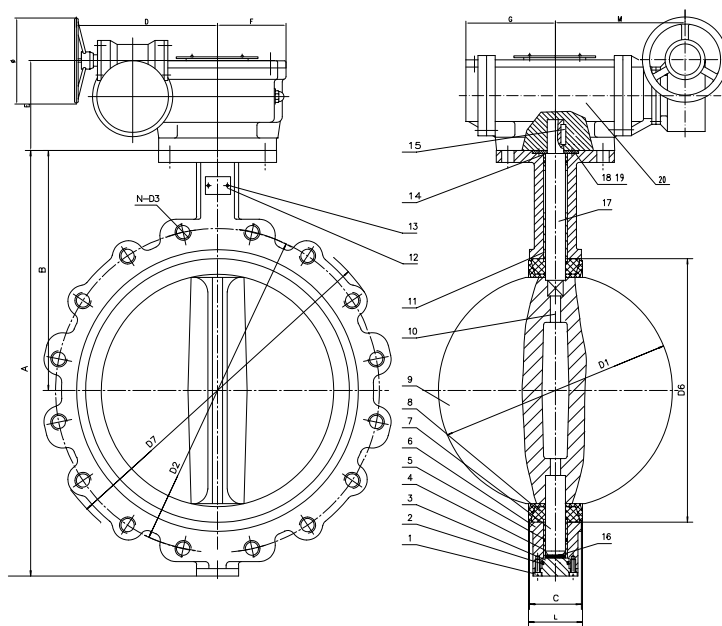

UNIT: mm

DN	D1	D2	D3	D6	D7	A	B	C	E	D	F	M	G	L	N	Ø	KEY	Wgt KG
DN350 (14")	333.3	470	M20			720	368	76.1		225	82	80	82	79.5		300		73
DN400 (16")	389.6	521	M24	439.52	589	798	400	102	130	268	110	181	110	106.3	12	300	10x56	119
DN450 (18")	440.5	584	M24	490.5	634	840	422	114	130	268	110	181	110	118.4	16	300	10x56	149
DN500 (20")	491.6	641	M24	535.43	704	930	480	130.28	130	268	110	181	110	135	16	300	10x56	220
DN600 (24")	592.5	756	M30	654.35	830	1124	562	151.36	137	301	136	200	136	156	16	400	16x70	277

Dimensions: Wafer Style

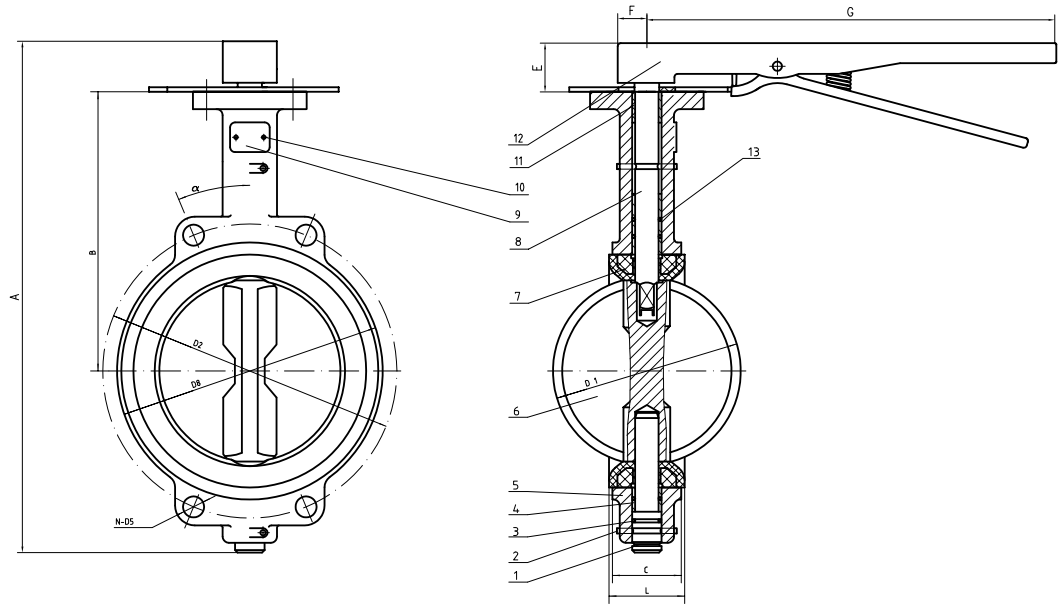

UNIT: mm

DN	D1	D2	N-D5	D8	A	B	C	E	L	F	G	a	Wgt KG
DN50 (2")	52.6	114	4-Ø18	100	310	161	43	32	45	12.7	252	45	3.8
DN65 (2.5")	54.3	127	4-Ø18	120	340	175	46	32	47.6	12.7	252	45	4.6
DN80 (3")	78.8	146	4-Ø18	127	345	181	45.21	32	49	12.7	252	45	5.2
DN100 (4")	104	178	4-Ø18	165	382	200	52.07	32	54.7	16	252	22.5	6.2
DN125 (5")	123.3	210	4-Ø18	185	410	213	55.5	32	58	19	252	22.5	8
DN150 (6")	155.7	235	4-Ø23	212	435	226	55.75	32	58.6	19	252	22.5	8.8
DN200 (8")	202.41	292	4-Ø23	268	517	260	60.58	45	63.4	31	359	22.5	16.4
DN250 (10")	250.42	356	4-Ø23	341	583	292	68	51	70	31	359	15	22
DN300 (12")	301.5	406	4-Ø26	400	667	337	76.9	51	80.1	31	359	15	35.4

Dimensions: Wafer With Gear Operator

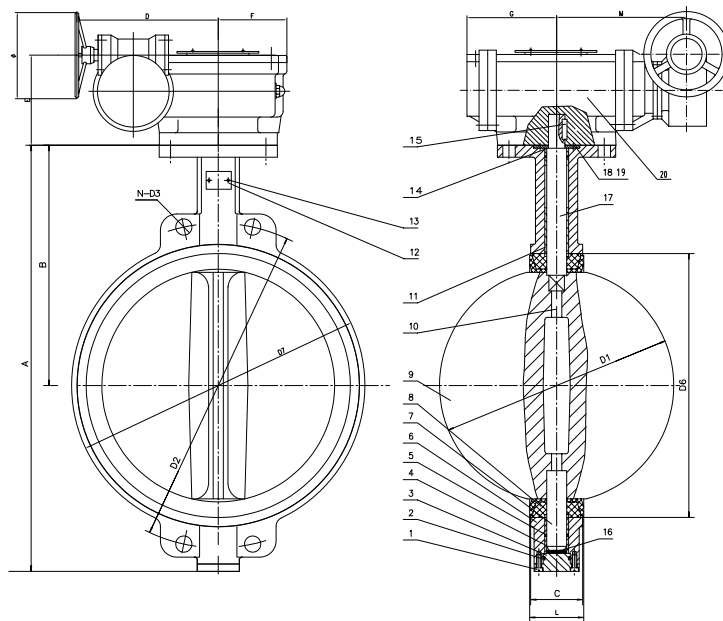

UNIT: mm

DN	D1	D2	D3	D6	D7	A	B	C	E	D	F	M	G	L	N	Ø	KEY	Wgt KG
DN350 (14")	333.3	470				720	368	76.1		225	82	80	82	79.5		300		66
DN400 (16")	389.6	521	Ø26	439.52	488	798	400	102	130	268	110	181	110	106.3	12	300	10x56	100
DN450 (18")	440.5	584	Ø26	490.5	539	840	422	114	130	268	110	181	110	118.4	16	300	10x56	138
DN500 (20")	491.6	641	Ø26	535.43	593	930	480	130.28	130	268	110	181	110	135	16	300	10x56	167
DN600 (24")	592.5	756	Ø33	654.35	816	1124	562	151.36	137	301	136	200	136	156	16	400	16x70	260

PEAKFLO - Butterfly Valve

A Full Range Of Pneumatic & Electric Actuators & Controls



Butterfly Valve Installation Procedure

1. Valve Location -

Butterfly valves should be installed if possible a minimum of 6 pipe diameters from other line elements, i.e., elbows, pumps, valves etc. Sometimes, 6 pipe diameters is not always practical, but it is important to achieve as much distance as possible. Where the butterfly valve is connected to a check valve or pump, use an expansion joint between them to ensure the disc does not interfere with the adjacent equipment.

2. Valve Orientation -

- In general, the valve should be installed with the stem in the vertical position and the actuator mounted vertically directly above the valve, however, there are those applications as discussed below where the stem should be horizontal. The valve should not be installed upside down.
- For slurries, sludge, mine tailings, pulp stock, dry cement and any media with sediment or particles, the valve should be installed with the stem in the horizontal position with the lower disc edge opening in the downstream direction.

3. Installation Procedure –

A. General Installation

- Make sure the pipeline and pipe flange faces are clean. Any foreign material such as pipe scale, metal chips, welding slag, welding rods etc, can obstruct disc movement or damage the disc or seat.
- The elastomer seat also acts as the gasket. Do not use additional gaskets as they will distort the seat.
- Align the piping and then spread the pipe flanges a distance apart so as to permit the valve body to be easily dropped between the flanges without contacting the pipe flanges.
- Check to see that the valve disc has been positioned to a partially open position, with the disc edge about 15mm from the face of the seat (approximately 10 degrees open).
- Insert the valve between the flanges, taking care not to damage the seat faces. Always pick the valve up by the locating holes or by using a nylon sling on the neck of the body. Never pick up the valve by the actuator or operator mounted on top of the valve.
- Place the valve between the flanges, centre it and then span the valve body with all flange bolts, but do not tighten the bolts. Carefully open the disc to the full open position, making sure the disc does not hit the adjacent pipe I.D. Now systematically remove jack bolts or flange spreaders and hand-tighten the flange bolts. Very slowly close the valve disc to ensure disc edge clearance from the adjacent pipe flange I.D. Now open the disc to full open and tighten all flange bolts per specification. Finally repeat a full close to full open rotation of the disc to ensure proper clearances.

B. Installation with Welded Flanges

When butterfly valves are to be installed between ANSI welding type flanges, care should be taken to abide by the following procedure to ensure no damage will occur to the seat –

- Place the valve between the flanges with the flange bores and valve body bore aligned properly. The discs should be in the 10 degrees open position.
- Span the body with the bolts.
- Take this assembly of flange-body-flange and align it properly to the pipe.
- Tack weld the flanges to the pipe.
- When tack welding is complete, remove the bolts and the valve from the pipe flanges and complete the welding of the flanges. Be sure to let the pipe and flanges cool before installing the valve.

NOTE: Never complete the welding process (after tacking) with the valve between pipe flanges. This causes severe seat damage due to heat transfer.

Asmuss Plastic Systems Limited

FREEPHONE: 0800 000 546 Facsimile: (64) (9) 477 - 2328

sales@plasticsystems.co.nz

34 Arrenway Drive, North Shore City 0632

P.O. Box 100244, North Shore City 0745, Auckland, NZ

